

Instructions

Data Board
WV-PB5548

Panasonic®

Before attempting to connect or operate this product, please read these instructions completely.

Caution

When handling this board, hold only by circuit board edges. Otherwise components on the board may be damaged by static electricity.

PREFACE

The WV-PB5548 Data Board is used to transmit/receive only control data between the Matrix Switcher and the camera site.

APPEARANCE

1. Data Connector (TA/TB/RA/RB/GND, 1 - 8)

These connectors are used to transmit/receive control data to/from the camera site. Use data grade cable, suitable for RS-485 (shielded, twisted pairs). Cable length may be extended up to 1,200 m (4,000 ft).

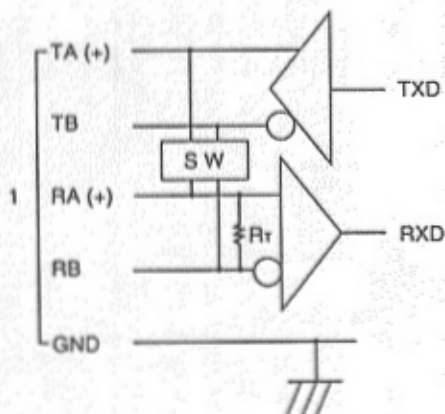

Rt: Termination Resistor, 150Ω 1/2W
SW: Selection Switch, Full Duplex/ Half Duplex
GND: Ground; Connected to each channel and common ground.

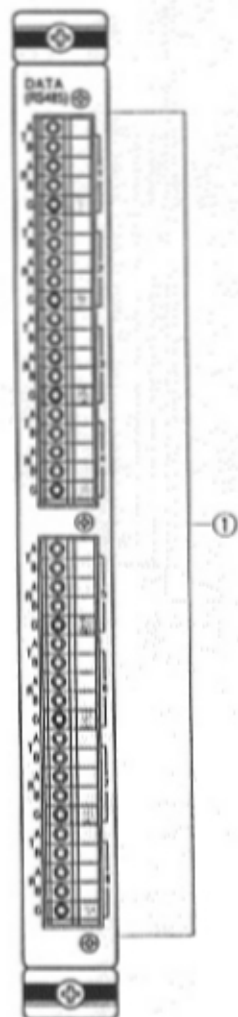

BOARD SETTING

Before installing this board, the following settings should be made by qualified service personnel or system installers.

- Set switches (SW1) on the board to meet the data board number as shown in the following table.
Initially, board number 1 is selected at the factory.

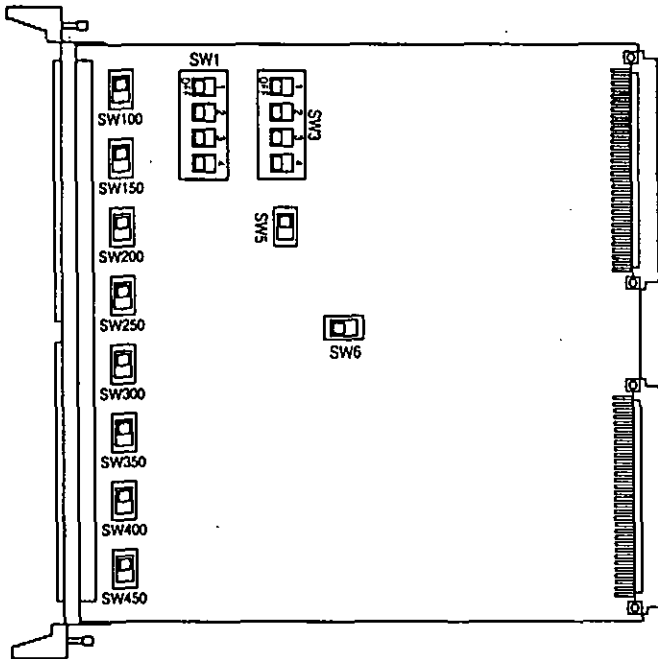

BOARD NO.	SW1 SETTING												
1	<table border="1"> <tr> <td>1</td> <td>2</td> <td>3</td> <td>4</td> </tr> <tr> <td><input type="checkbox"/></td> <td><input type="checkbox"/></td> <td><input type="checkbox"/></td> <td><input type="checkbox"/></td> </tr> <tr> <td colspan="4">OFF</td> </tr> </table>	1	2	3	4	<input type="checkbox"/>	<input type="checkbox"/>	<input type="checkbox"/>	<input type="checkbox"/>	OFF			
1	2	3	4										
<input type="checkbox"/>	<input type="checkbox"/>	<input type="checkbox"/>	<input type="checkbox"/>										
OFF													
2	<table border="1"> <tr> <td>1</td> <td>2</td> <td>3</td> <td>4</td> </tr> <tr> <td><input type="checkbox"/></td> <td><input type="checkbox"/></td> <td><input type="checkbox"/></td> <td><input type="checkbox"/></td> </tr> <tr> <td colspan="4">OFF</td> </tr> </table>	1	2	3	4	<input type="checkbox"/>	<input type="checkbox"/>	<input type="checkbox"/>	<input type="checkbox"/>	OFF			
1	2	3	4										
<input type="checkbox"/>	<input type="checkbox"/>	<input type="checkbox"/>	<input type="checkbox"/>										
OFF													
3	<table border="1"> <tr> <td>1</td> <td>2</td> <td>3</td> <td>4</td> </tr> <tr> <td><input type="checkbox"/></td> <td><input type="checkbox"/></td> <td><input type="checkbox"/></td> <td><input type="checkbox"/></td> </tr> <tr> <td colspan="4">OFF</td> </tr> </table>	1	2	3	4	<input type="checkbox"/>	<input type="checkbox"/>	<input type="checkbox"/>	<input type="checkbox"/>	OFF			
1	2	3	4										
<input type="checkbox"/>	<input type="checkbox"/>	<input type="checkbox"/>	<input type="checkbox"/>										
OFF													
4	<table border="1"> <tr> <td>1</td> <td>2</td> <td>3</td> <td>4</td> </tr> <tr> <td><input type="checkbox"/></td> <td><input type="checkbox"/></td> <td><input type="checkbox"/></td> <td><input type="checkbox"/></td> </tr> <tr> <td colspan="4">OFF</td> </tr> </table>	1	2	3	4	<input type="checkbox"/>	<input type="checkbox"/>	<input type="checkbox"/>	<input type="checkbox"/>	OFF			
1	2	3	4										
<input type="checkbox"/>	<input type="checkbox"/>	<input type="checkbox"/>	<input type="checkbox"/>										
OFF													
5	<table border="1"> <tr> <td>1</td> <td>2</td> <td>3</td> <td>4</td> </tr> <tr> <td><input type="checkbox"/></td> <td><input type="checkbox"/></td> <td><input type="checkbox"/></td> <td><input type="checkbox"/></td> </tr> <tr> <td colspan="4">OFF</td> </tr> </table>	1	2	3	4	<input type="checkbox"/>	<input type="checkbox"/>	<input type="checkbox"/>	<input type="checkbox"/>	OFF			
1	2	3	4										
<input type="checkbox"/>	<input type="checkbox"/>	<input type="checkbox"/>	<input type="checkbox"/>										
OFF													
6	<table border="1"> <tr> <td>1</td> <td>2</td> <td>3</td> <td>4</td> </tr> <tr> <td><input type="checkbox"/></td> <td><input type="checkbox"/></td> <td><input type="checkbox"/></td> <td><input type="checkbox"/></td> </tr> <tr> <td colspan="4">OFF</td> </tr> </table>	1	2	3	4	<input type="checkbox"/>	<input type="checkbox"/>	<input type="checkbox"/>	<input type="checkbox"/>	OFF			
1	2	3	4										
<input type="checkbox"/>	<input type="checkbox"/>	<input type="checkbox"/>	<input type="checkbox"/>										
OFF													
7	<table border="1"> <tr> <td>1</td> <td>2</td> <td>3</td> <td>4</td> </tr> <tr> <td><input type="checkbox"/></td> <td><input type="checkbox"/></td> <td><input type="checkbox"/></td> <td><input type="checkbox"/></td> </tr> <tr> <td colspan="4">OFF</td> </tr> </table>	1	2	3	4	<input type="checkbox"/>	<input type="checkbox"/>	<input type="checkbox"/>	<input type="checkbox"/>	OFF			
1	2	3	4										
<input type="checkbox"/>	<input type="checkbox"/>	<input type="checkbox"/>	<input type="checkbox"/>										
OFF													
8	<table border="1"> <tr> <td>1</td> <td>2</td> <td>3</td> <td>4</td> </tr> <tr> <td><input type="checkbox"/></td> <td><input type="checkbox"/></td> <td><input type="checkbox"/></td> <td><input type="checkbox"/></td> </tr> <tr> <td colspan="4">OFF</td> </tr> </table>	1	2	3	4	<input type="checkbox"/>	<input type="checkbox"/>	<input type="checkbox"/>	<input type="checkbox"/>	OFF			
1	2	3	4										
<input type="checkbox"/>	<input type="checkbox"/>	<input type="checkbox"/>	<input type="checkbox"/>										
OFF													

- Set switches (SW100/SW150/SW200/SW250/SW300/SW350/SW400/SW450) on the board to choose the communication lines as either Full Duplex (FULL) or Half Duplex (HALF).
Initially, Full Duplex(FULL) positions are selected at the factory.

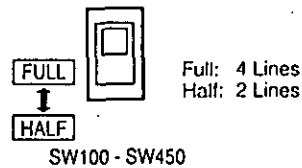

- Set switch (SW5) on the board to choose the LED indicator as either "ON" or "OFF" mode. The indicator displays that the control data are activated normally on the board.
Initially, "ON" position is selected at the factory.

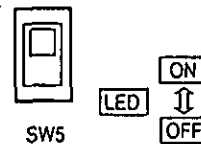

- Confirm switches (SW3/SW6) on the board are set to the following positions.

Note
These switches are used only for factory test.
Always keep these switches in these positions in the field.

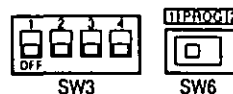

INSTALLATION

Caution

Before installing this board be sure to turn off the Power Switch of the Matrix Switcher.

The following installation should be made by qualified service personnel or system installers.

1. Remove the screws from the rear panel(s) of the Matrix Switcher.
2. Remove the rear panel(s).
3. Place the Data Board into the desired position in the rear of Matrix Switcher by sliding it inside the board guides.

Note

Each slot is identical, so the board can installed in any slot. However it is recommended to install the board as shown below for an orderly installation.

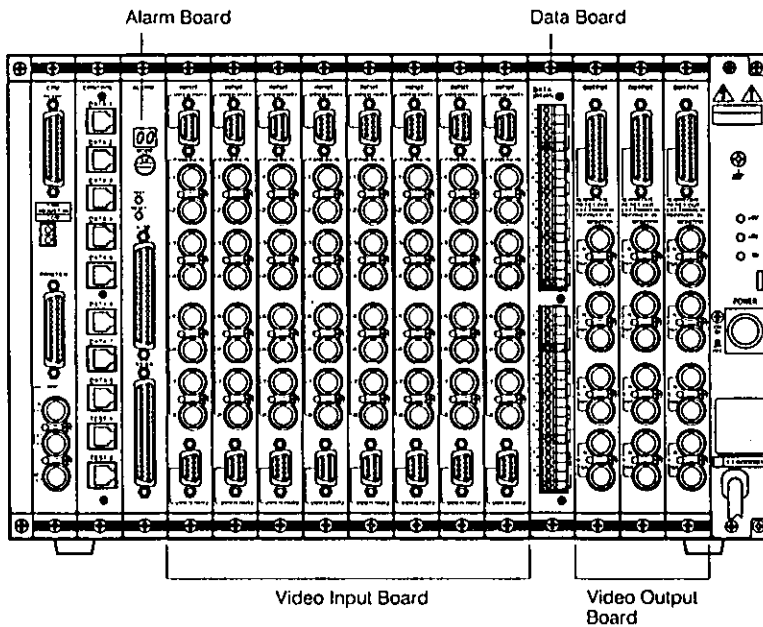
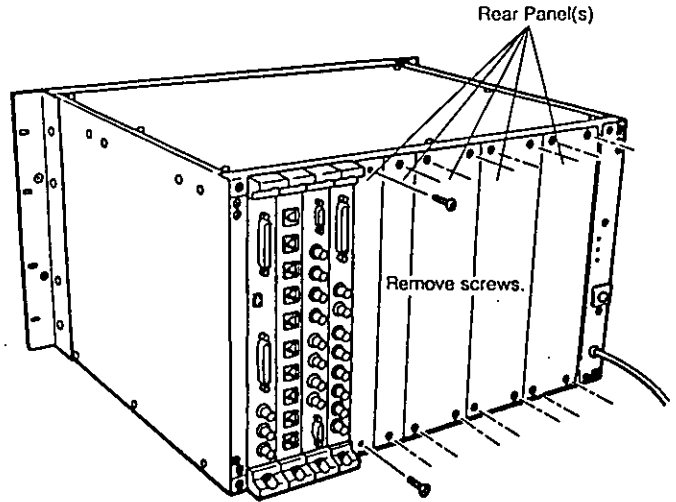

4. Make sure to push in the Data Board until it is seated firmly.
5. Secure the Data Board by tightening the two screws on the board.
6. Close off open spaces on the rear of the Matrix Switcher by using WV-Q63 Blank Panels (Optional) or supplied rear panel(s).
(Refer to the instructions for WV-Q63)

Note

Refer to the Operating Instructions of WJ-SX550A for further details.

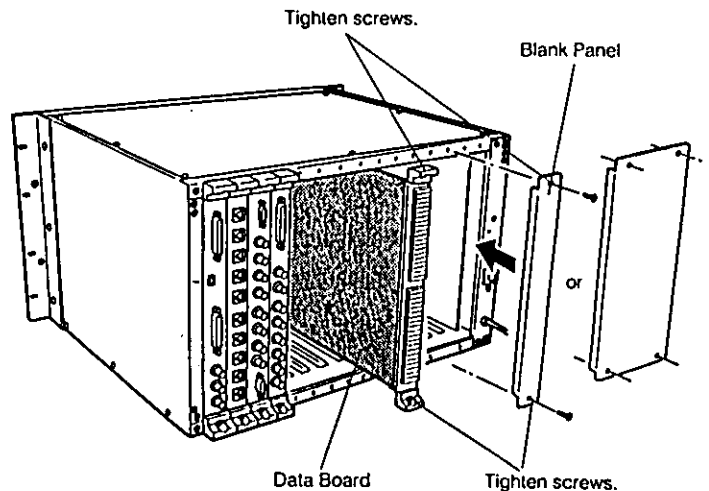

CONNECTIONS

Connect the Data Board and the Camera Controller by specified data cable.
Basically, connect shown right.

Then the following settings should be made by using the Setup Menu.

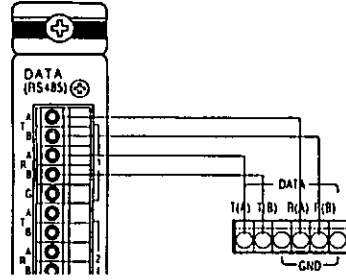

• Camera Controller

Daisy		Off							
Camera In Number	F/H Duplex	Delay Time	Baud Rate	Wait Time	Data Bit	Parity Check	Stop Bit		
#1	02	Full	Off	19200	Off	8	None	1	
#2	04	Half	Off	9600	Off	8	None	1	
#3	06	Full	100	19200	Off	8	None	1	
#4		Full	Off	19200	Off	8	None	1	
#5	10	Full	Off	1200	Off	8	None	1	
#6		Full	Off	19200	Off	8	None	1	
#7		Full	Off	19200	Off	8	None	1	
#8		Full	Off	19200	Off	8	None	1	

When Daisy Mode is "on" only #1 will be available.

F1:-- F2:-- F3:DEL F4:Pop Up

```

** Communication **
Unit Number 1
Baud Rate 19200
Data Bit 8
Parity Check None
Stop Bit 1
Xon/Xoff Not Use
Wait Time Off
Delay Time Off
Alarm Data Off
Return
    
```

■ Direct Connection between the Data Board and Camera Controllers

In this type of connection there is one control cable directly connecting each Data Connector to the WV-RM70 Camera Controller. Refer to the connections and settings shown below.

• 4 Line (Full Duplex) Connection

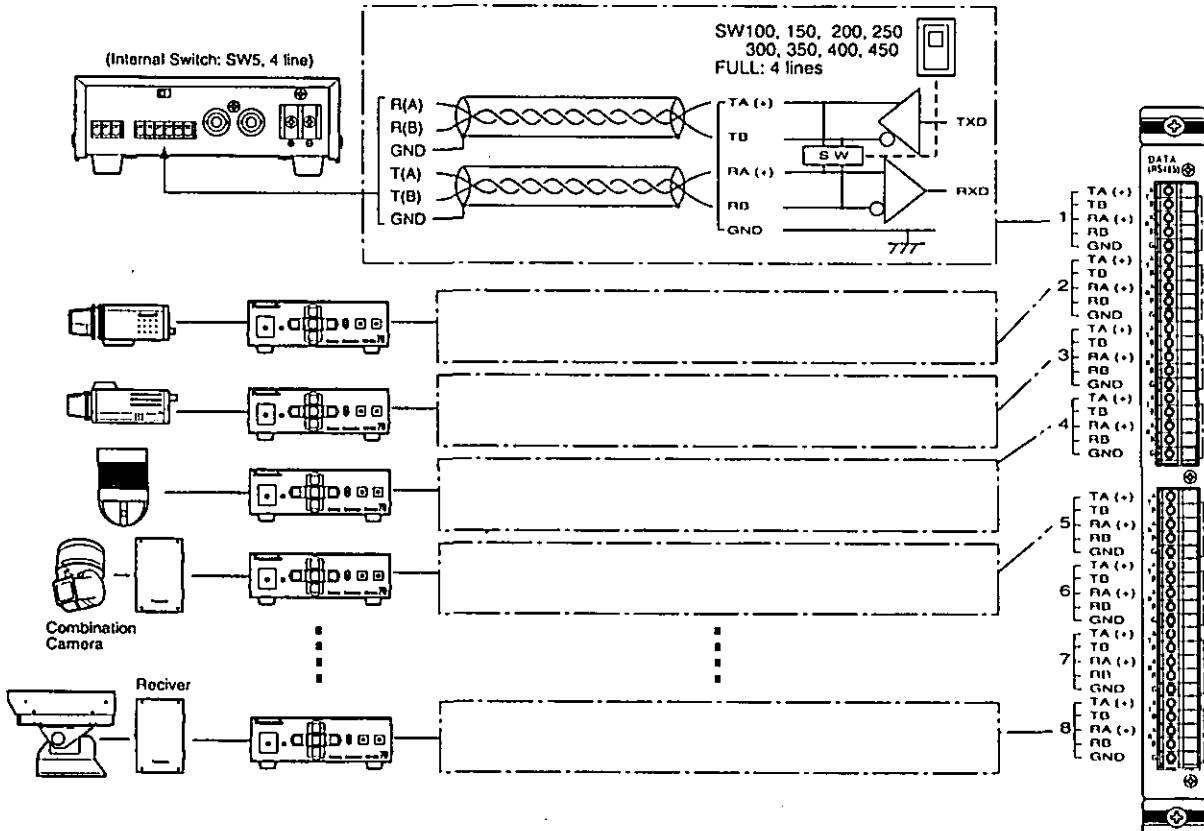

• 2 Line (Half Duplex) Connection

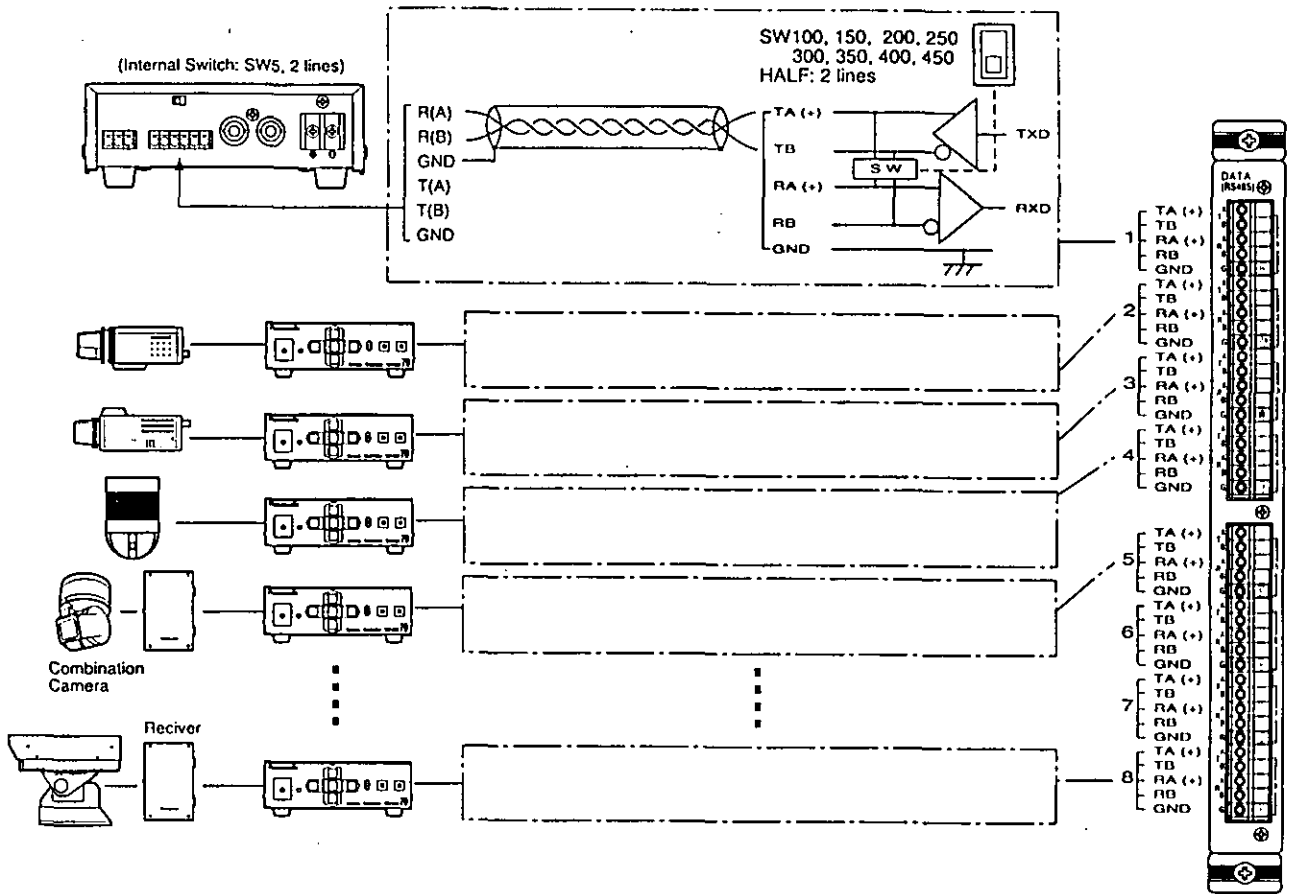

Set the same Communication Parameters on the Setup Menus of the Matrix Switcher and Camera Controller.

Parameters	Models	Matrix Switcher WJ-SX550A	Camera Controller WV-RM70
		F/H Duplex : Full or Half	
Baud Rate		19200	19200
Data Bit		8	8
Parity Check		None	None
Stop Bit		1	1
Wait time		Off	Off
Delay Time		Off	Off
			Xon/Xoff : Not use
			Alarm Data : On
		Daisy : Off	Unit Number : Not use

■ Indirect Connection between the Data Board and Camera Controllers ("Daisy-Chain" Type Wiring)

In this type of connection only one control cable directly connects between the Data Connector #1 and the Camera Controller #1. The rest of the Camera Controllers connect to Camera Controller #1 in a Daisy-Chain of connection. Refer to the connections and settings shown below.

• 4 Line (Full Duplex) Connection

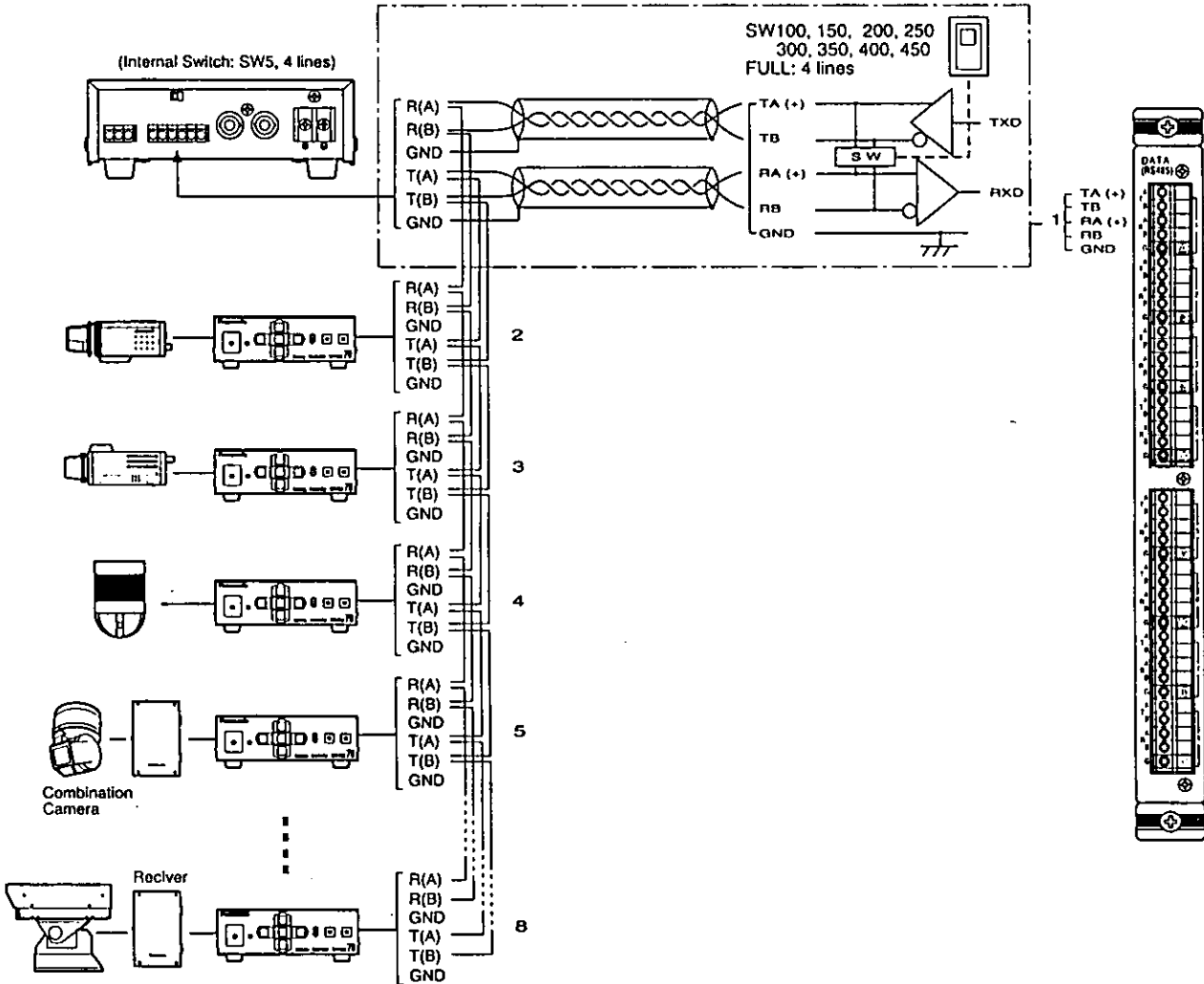

Set the Matrix Switcher and the Camera Controllers (up to 8) shown below.

Parameters	Models	Matrix Switcher WJ-SX550A	Camera Controller WV-RM70
Daisy	: On	F/H Duplex : Full Camera In Number #1 --- Camera In Number #2 --- Camera In Number #3 --- Camera In Number #4 --- Camera In Number #5 --- Camera In Number #6 --- Camera In Number #7 --- Camera In Number #8 ---	Unit Number : 1 Unit Number : 2 Unit Number : 3 Unit Number : 4 Unit Number : 5 Unit Number : 6 Unit Number : 7 Unit Number : 8

Note

It is not available 2 Line (Half Duplex) connection in a Daisy-Chain.

Caution

It is only available an alarm data connected unit in a Daisy-Chain. Set the Mode Selection Switch on the one of Camera Controllers to the "NORMAL" position and the others are set to the "ALARM OFF" positions.

SPECIFICATIONS

Data Input/Output(1 - 8): RS-485 (Full Duplex or Half Duplex, selectable inside the switch)
[5-pin T(A), T(B), R(A), R(B), GND] X8
use with shield, twisted pairs data cable
Transmitting Speed (Baud Rate); 1200 - 19200 bps

Max. Cable Length: 1,200 m (4,000 ft)

Max. Number Boards: 8 (Address 1 - 8, Total 1 - 64 Data Input/Output)

Dimensions: 24.5 (W) x 265 (H) x 260 (D) mm
15/16" (W) x 10-7/16" (H) x 10-1/4" (D)

Weight: 400g (0.9 lbs.)

Weight and dimensions indicated are approximate.
Specifications are subject to change without notice

Panasonic

Broadcast & Television Systems Company

Division of Matsushita Electric Corporation of America

IMAGING SYSTEMS DIVISION

Executive Office: One Panasonic Way JE-7, Secaucus, New Jersey 07094

Regional Offices:

Northeast: 43 Hartz Way, Secaucus, NJ 07094 (201) 348-7303

Southeast: 1225 Northbrook Parkway, Suite 1-160, Suwanee, GA 30174 (770) 338-6835

Midwest: 1707 North Randall Road, Elgin, IL 60123 (708) 468-5200

Southwest: 4500 Amon Carter Blvd., Fort Worth, TX 76155 (817) 685-1117

Western: 6550 Katiella Ave. 17A-5, Cypress, CA 90630 (714) 373-7265

MATSUSHITA ELECTRIC OF CANADA LIMITED

5770 Ambler Drive, Mississauga, Ontario, L4W 2T3 Canada (905)624-5010

PANASONIC SALES COMPANY

DIVISION OF MATSUSHITA ELECTRIC OF PUERTO RICO, INC.

San Gabriel Industrial Park, 65th Infantry Ave. KM. 9.5 Carolina, Puerto Rico 00630 (809)750-4300